



# Operating Manual

**Model 957  
Ionised Air Curtain**



# Contents

Introduction	3
General notes on Operation	4
Distance from the Object	6
Intervening Objects	6
Installation	6
Air Supply	7
CE Approval	8
Health and Safety	8
Maintenance	9
Cleaning your Ionisor	9

Products shown in this document may be covered by one or more patents, patents applied for and/or registered designs and/or trade marks. For further information please refer to our Head Office or visit [www.meech.com](http://www.meech.com).



# Introduction



Meech Ionised Air Curtains have unique static elimination capabilities and will give many years of excellent service, provided that the following instructions are observed closely.

## General Notes On Operation

The typical Meech air curtain installation consists of one or more ionised air curtains connected to a Meech power unit.

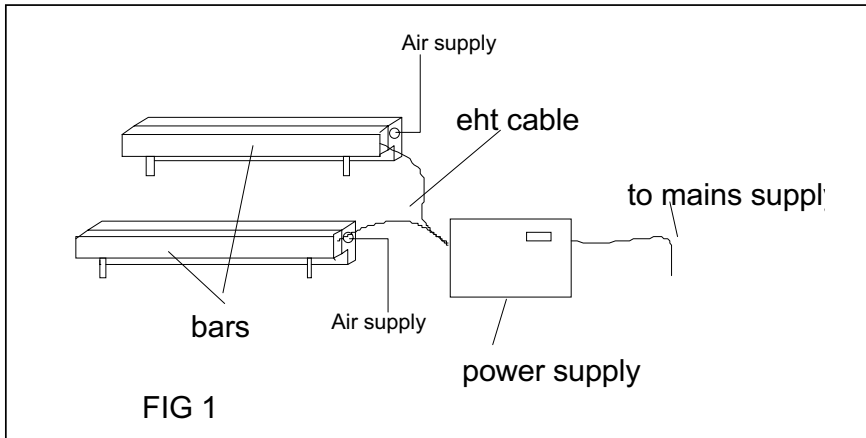

The static eliminator bar may be either an RML Model 910 (Green) or an HER Model 920 (Red). This bar converts the energy from the power unit to generate an ionised air corona. The corona is transported to the object by the air flow.

When a statically charged object enters the ionised air corona, the free moving ions are attracted to the opposite charge on the object. In this way the static electricity is neutralised. Unused ions in the corona recombine or are discharged to earth.

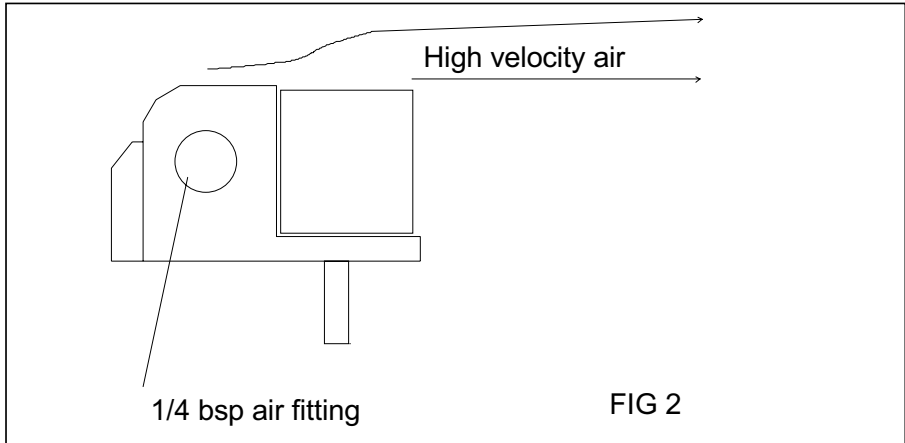

# Installation

The correct positioning of the air curtain is vital to its efficient operation. Please observe the following instructions.

## Distance From The Object

The air curtain should be positioned as close as possible to the object to be neutralised.

If we say that the neutralisation power at a distance of 10cm is 100% then the relative neutralisation performance at a longer distance is:

<b>Distance From Object</b>	<b>Relative Performance</b>
30 cm	90 %
50 cm	50 %
100 cm	20 %

## Intervening Objects

If the ionised air is blown through earthed objects eg a machine frame or cross rods, these will absorb some of the ionisation and so reduce the neutralisation power. Avoid this where possible.



# Air Supply

- a. The air supply must be clean and dry. A 5 micron coalescing filter is recommended. The Meech guarantee does not cover damage due to water or oil in the air supply.
  
- b. Reduce the air supply to the lowest pressure which achieves the required results. Excessive air is wasteful and also dilutes the ionisation unnecessarily.
  
- c. The female thread for the air fitting is 1/4 BSP.

Air Pressure	Consumption Per 150mm	Volume Out Per 150 mm	Air Speed
1 bar	238 lit/min	5950 lit/min	250 m/min
2 bar	336 lit/min	8400 lit/min	530 m/min
3 bar	448 lit/min	11200 lit/min	848 m/min
4 bar	500 lit/min	11400 lit/min	1363 m/min

**Caution:** When used in conjunction with a model 920 HER ionising bar this equipment will give an electrical shock if the pins are touched. The following procedure must be followed.

**The supply voltage of the power supply must be interlocked with the ON/OFF control of the machine to which the equipment is fitted.**

This will ensure that whilst the machine is switched off and thus operatives may gain access to the machine and our equipment there will be no danger of operatives receiving shocks from our equipment.

It is assumed that normal safety barriers are in place on the machine to ensure that operatives are unable to access the machine and hence our equipment whilst the machine is switched ON.

## CE Approval

A CE Declaration of Conformity for this product exists in respect of the Low Voltage Directive:72/23/EEC (“LVD”) & Electrtomagnetic Compatibility Directive: 89/336/EEC (“EMCD”)



## Health and Safety

Emission of Ozone: Considerably below international standard of 0.1ppm.

# Maintenance

## Cleaning your Meech Ioniser

Ionisers require periodic cleaning. During normal operation, dirt will build-up on the emitter pins and upon the body of the ioniser. This will cause a reduction in performance.

Typically, weekly cleaning is sufficient. However, equipment used in some heavy contamination areas, such as gravure printing or where plastic fumes are present, may require daily cleaning. Equally, in a Class 100 area, cleaning may only be required on a monthly basis. Advanced systems with performance monitoring, e.g 977cm and 904cm, will alert the operator to the need to clean the equipment before performance drops to an unacceptable level.

Before cleaning, ensure that the equipment is switched off.

Emitter pins can be cleaned very effectively with a brush. A dry toothbrush is ideal.

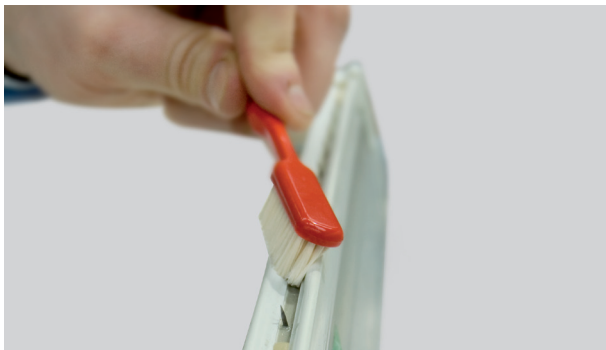

Ionising bars will need periodic wiping to clean grey deposits from the surface of the bar. A cloth moistened with a small amount of IPA or methylated spirits is recommended.











#### **Meech International (UK)**

2 Network Point  
Range Road, Witney  
OX29 0YN, UK

Tel: +44 (0)1993 706700  
Fax: +44 (0)1993 776977  
email: sales@meech.com

#### **Meech CE**

2151 Fót  
Széchenyi út. 46  
Hungary

Tel: +36 27535075  
Fax: +36 27535076  
email: ce@meech.com

#### **Meech Static Eliminators USA Inc**

2915 Newpark Drive  
Norton, OH 44203  
USA

Tel: +1 330 564 2000 / 1 800 232 4210  
Fax: +1 330 564 2005  
email: info@meech.com

#### **Meech Static Eliminators (Shanghai) Co. Ltd**

Room 205, Huana Hotel Office Tower  
No. 1733 Lianhua Road  
Shanghai 201103  
China

Tel: +86 400 820 0102  
Fax: +86 400 820 0102\*201  
email: china@meech.com

#### **Meech Elektrostatik SA**

Kaiserbaracke 66  
B-4780 St.Vith  
Belgium

Tel: +32 8086 2983  
Fax: +32 8086 2821  
email: mesa@meech.com

#### **Meech Shavotech**

Shavo House, Survey No.21A / 10 B, Plot No.394  
South Main Road, Koregaon Park,  
PUNE 411 001  
India

Tel: 020-26069641/ 26069642.  
Fax: 020-26069644  
e-mail: india@meech.com