



# Operating Manual

**Model 915**

**Shockless AC Bar**



# Contents

Introduction	3
Inspection	4
Operation	5
Installation	6
Technical Data and Construction	9
CE Approval	9
Maintenance	10
Health and Safety	10
Fault Finding	11
Repairs and Warranty	16

Products shown in this document may be covered by one or more patents, patents applied for and/or registered designs and/or trade marks. For further information please refer to our Head Office or visit [www.meech.com](http://www.meech.com).



# Introduction

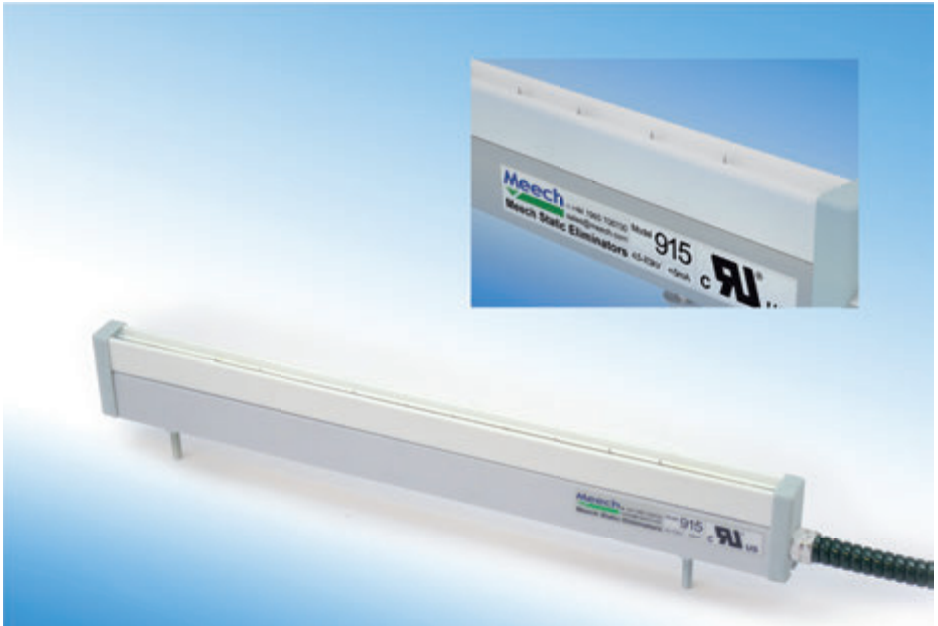

The Meech Model 915 has been designed for use on the most arduous static elimination problems. The special resistive coupling of its emitter pins renders them shockless, whilst giving powerful static neutralisation performance. This enables the bar to eliminate very high static charges on high speed webs and at longer ranges than has previously been possible.

# Inspection

The Model 915 Bar was carefully packed at the factory. Nevertheless, we recommend careful examination of the carton and contents for any damage. If damage is evident, keep the packing material and immediately notify the carrier of a possible damage claim. Shipping claims must be made by the consignee to the delivering carrier.

# Operation

The typical Meech Model 915 installation consists of one or more bars connected to a Meech Model 904 Power Unit.

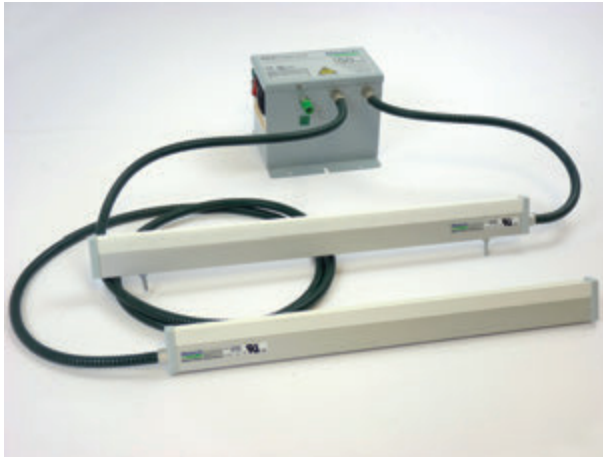

The Power Unit converts the electrical supply into a high voltage, low amperage output. This output energy is transferred to the 915 bar by the HT cable.

The resistively coupled electrodes are energised by the AC voltage from the Power Unit. The electrodes emit this energy (corona discharge) in the form of a field of ionised air. This ionised air supplies ions of both polarities.

Electrostatically charged products which pass through this corona are immediately neutralised and become static free.

Under test conditions, the Meech Model 915 has been found to give charge decay times that are up to eight times faster than standard AC shockless eliminator bars.

# Installation

The 915 Bar can be placed between 25mm and 150 mm from the surface to be neutralised. It is important to ensure that the target surface has free air on both sides and that earthed metal objects are, where possible, at least 20 mm away from the bar. These precautions will maximise the unit's ionisation capability.

Good results can be achieved at distances up to 150mm but as the distance from the object increases, the speed of charge neutralisation will decrease.

A typical installation distance is 50mm from the target surface. This gives excellent performance at high web or product speeds, whilst avoiding possible damage from web breaks or product mis-feeds. Very fast webs may require the bar to be as close as 25mm to the web.

Correct positioning of the bar(s) is vital to efficient operation. The following diagrams show the correct installation procedures:

1. The optimal distance from material to be neutralised.

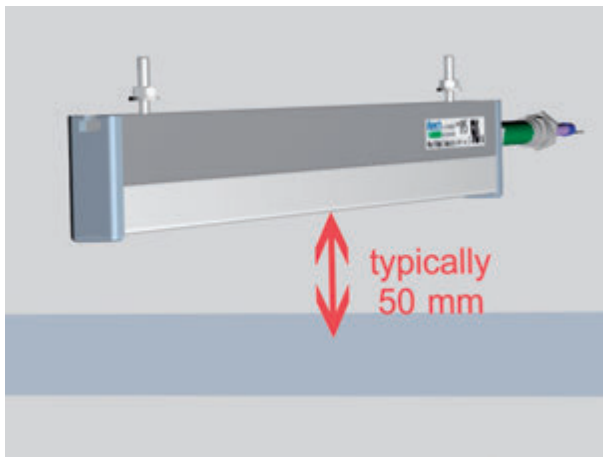



Mounting of the bar is by 20mm M4 studs mounted in a track at the rear of the bar. These can be slid to any point along the bar's length to meet the machine's available fixing points.

The chassis of the bar is electrically connected to ground on the power unit via the flexible armoured conduit. However, it is good practice to provide a secondary grounding through the fixing points where practical.

The HT cable and armoured conduit require connection to a Meech model 904 power unit. Please consult the 904 instruction manual for further instruction.

1. Free space is required on opposite sides of the target material, not a roller or solid object.

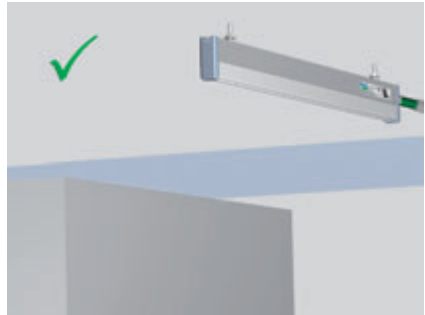
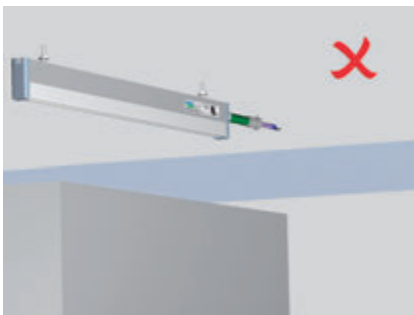
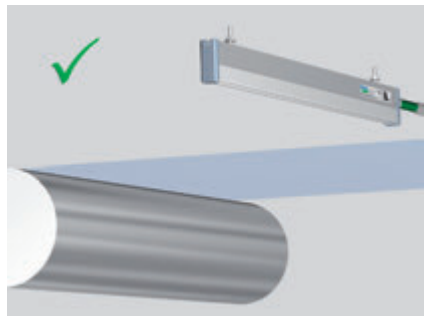
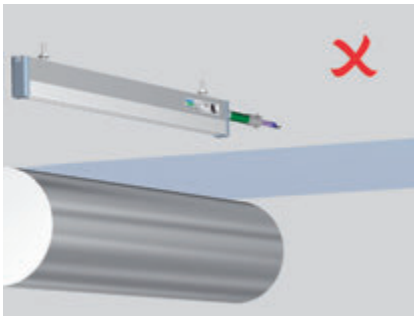

2. Avoid proximity to earthed parts of machinery as this will distort the corona and reduce its efficiency.

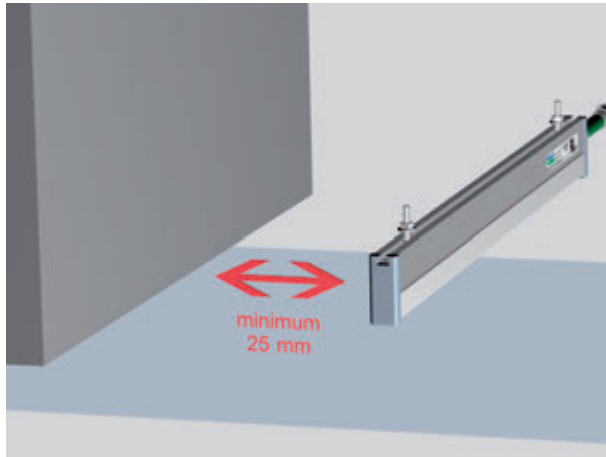

3. If bars are needed on both sides of the material, they should be staggered.

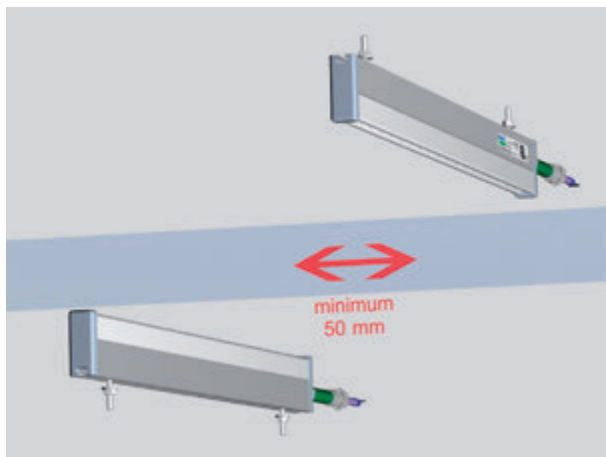

4. The bars must be earthed for correct operation. If in any doubt run an earth wire from the bar to the earth stud on the Power Unit.

# Technical and Construction

Operating voltage	:	4.5 - 7.0 kV
Max temperature	:	60°C
Length	:	Available in lengths from 80 mm to 4000 mm Overall length is 60mm greater than the effective length.
Cable	:	2 metres shielded in flexible conduit; longer lengths can ordered.
Weight	:	Approx 1,100gms per 1000mm length
Cross section	:	18mm x 42mm (inc. of end caps)
Construction	:	Anodised aluminium and fire retardant PVC extrusion.
Emitter Points	:	Titanium
Mounting	:	M4x20mm studs. These are located in a channel to provide universal mounting points.
Operating range	:	30 - 150mm

## CE Approval

A CE Declaration of Conformity for this product exists in respect of the Low Voltage Directive: 72/23/EEC ("LVD") & Electromagnetic Compatibility Directive: 89/336/EEC ("EMCD")



# Maintenance

Ionisers require periodic cleaning. During normal operation, dirt will build-up on the emitter pins and upon the body of the ioniser. This will cause a reduction in performance.

Typically, weekly cleaning is sufficient. However, equipment used in some heavy contamination areas, such as gravure printing or where plastic fumes are present, may require daily cleaning. Equally, in a Class 100 area, cleaning may only be required on a monthly basis. Advanced systems with performance monitoring, e.g 977CM and 904CM, will alert the operator to the need to clean the equipment before performance drops to an unacceptable level.

Before cleaning, ensure that the equipment is switched off.

Emitter pins can be cleaned very effectively with a brush. A dry toothbrush is ideal.

Ionising bars will need periodic wiping to clean grey deposits from the surface of the bar. A cloth moistened with a small amount of IPA or methylated spirits is recommended.

Should you have any additional questions regarding the maintenance of Meech equipment please contact Meech International directly or your local Meech distributor.



# Health and Safety

# Fault Finding

Tests must be completed by a qualified electrical engineer.

If in doubt please contact Meech head office or your local distributor.

**CAUTION:** Whilst no danger to personnel exists, it is essential that, with the exception of bars with a water resistant option, high voltage ionising equipment, makes no contact with water or water based fluids. Should such an event occur, disconnect immediately and return equipment to the manufacturer for water damage assessment.

The Model 915 ionising bar forms part of a system, comprising the bar itself and a Model 904 Power Unit. (See Fig 2)

To verify where a fault may have occurred it is important to test each item of the system individually. Should more than one bar be connected to a power unit, these must be tested individually.

To check the Model 915 bar follow the procedure detailed below.

1. Switch off the electrical supply to the system and disconnect the IEC plug.



2. Disconnect all ionising bars from the power unit.



3. Follow the test procedure for the Model 904 Power Unit. This can be found in the instruction manual of the Model 904.



4. Having checked the power unit reconnect one Model 915 ionising bar.
5. Using a high voltage probe and meter measure the voltage on the pins of the ionising bar. This voltage should be approximately 6.5 kV.

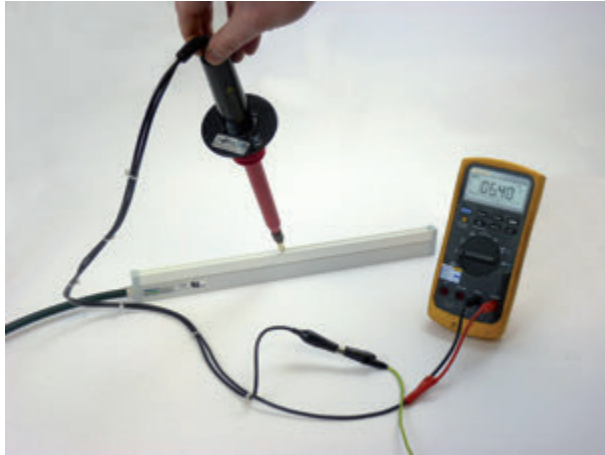

6. If the voltage is below 4.0 kV then the bar should be returned to Meech for service and/or repair.

7. If no meter and probe is available, then a fast and simple test can be undertaken by shorting a pin of the bar to earth.

- Attach a short length of insulated wire to either fixing stud on the bar.



- Holding the wire insulation, approach any of the bar emitter pins with the bare end of the wire.

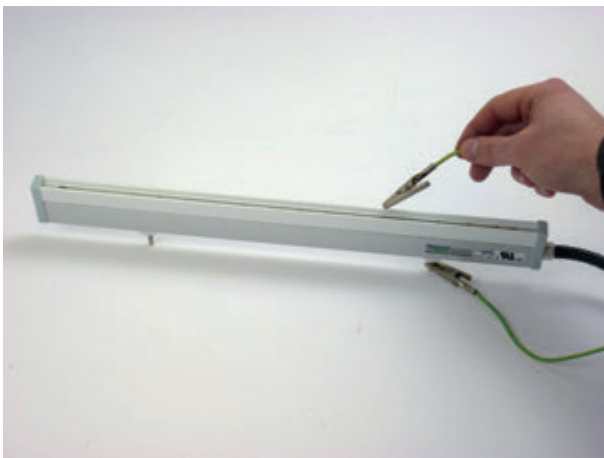

- As the pin is approached, a small faint spark should jump from the pin to the wire.



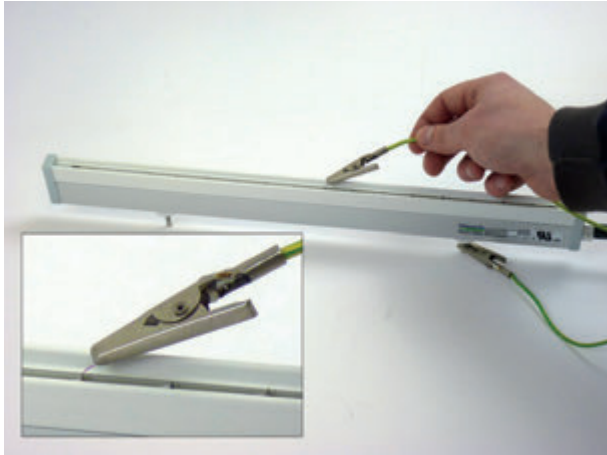

- As the spark is drawn a slight buzzing sound will also be heard. This indicates that the bar is functioning correctly.
8. If there is more than one bar to test, disconnect the first item and repeat the above steps with subsequent bars.

# Repairs And Warranty

The 915 bar is warranted by Meech Static Eliminators Ltd to the original purchaser against defects in material and workmanship for one year after purchase. Should any malfunction occur, please return the bar directly to Meech Static Eliminators or your local distributor. All products returned to the factory MUST be accompanied by a return authorisation number and must be shipped prepaid. For prompt service, ship the unit to the factory with the return authorisation number shown clearly on the label. Be sure it is well packed in a sturdy carton with shock absorbing material.

Include a note stating the nature of the problem as specifically as possible, and also include instructions for returning the bar to you. We will pay one-way return surface shipping costs on any repairs covered under the warranty.

Field repairs should not be undertaken during the warranty period. Repair attempts by unqualified personnel will invalidate the warranty.





#### **Meech International (UK)**

2 Network Point  
Range Road, Witney  
OX29 0YN, UK

Tel: +44 (0)1993 706700  
Fax: +44 (0)1993 776977  
email: sales@meech.com

#### **Meech CE**

2151 Föt  
Széchenyi út. 46  
Hungary

Tel: +36 27535075  
Fax: +36 27535076  
email: ce@meech.com

#### **Meech Static Eliminators USA Inc**

2015 Newpark Drive  
Norton, OH 44203  
USA

Tel: +1 330 564 2000 / 1 800 232 4210  
Fax: +1 330 564 2005  
email: info@meech.com

#### **Meech Static Eliminators (Shanghai) Co. Ltd**

7G, 7F, LP Tower  
#25 Xiangfeng Road  
201103 Shanghai  
China

Tel: +86 400 820 0102  
Fax: +86 21 6405 7736  
email: china@meech.com

#### **Meech Elektrostatik SA**

Kaiserbaracke 66  
B-4780 St.Vith  
Belgium

Tel: +32 8086 2983  
Fax: +32 8086 2821  
email: mesa@meech.com

#### **Meech Shavotech**

Shavo House, Survey No.21A / 10 B, Plot No.394  
South Main Road, Koregaon Park,  
PUNE 411 001  
India

Tel: 020-26069641/ 26069642,  
Fax: 020-26069644  
e-mail: india@meech.com